

Ignition Coil

TYPE:TR06-S006

Applications:

- GAS IGNITER.
- AIR CLEANER.
- O₃ LAMP.

※Remark:Below here which specific could depend on customized specifications are acceptable.

MECHANICAL DIMENSION:

UNIT mm

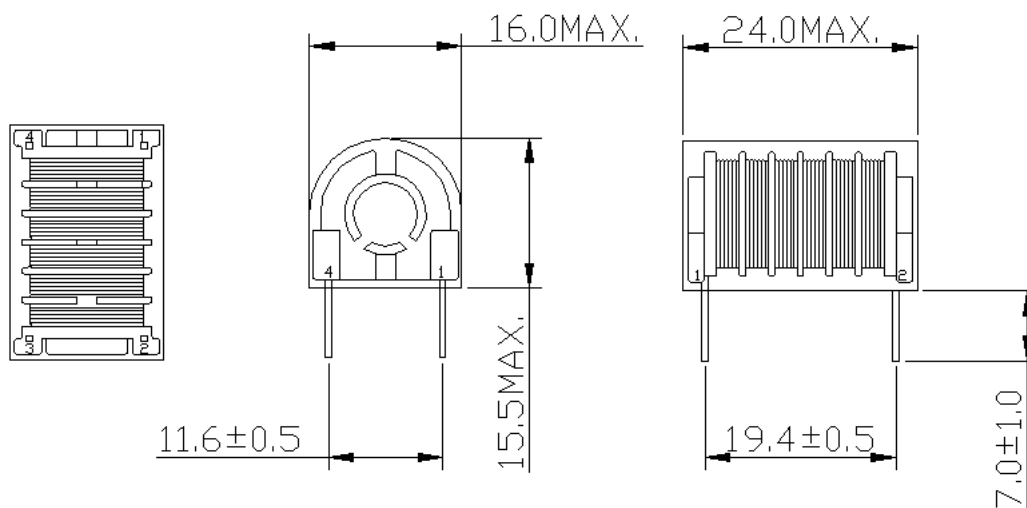

P/N	L _{pri.}	L _{sec.}	DCR _{pri.}	DCR _{sec.}	TURNS RATIO	WEIGHT
JC-93096	7.5μH±15%	345mH±15%	36mΩ MAX.	960Ω MAX.	1:262	11.2 g

JET CHAM ENTERPRISE CO.,LTD

ADDRESS: 3F. NO.41 CHIAU AN ST. CHUNG HO DIST .NEW TAIPEI CITY, TAIWAN R.O.C.

OFFICE TEL:886-2-29253396 ~ 7 FAX.:886-2-29288877

FACTORY TEL:886-2-22447326 ~ 7 FAX.:886-2-22447328

E-mail: jetcham@ms35.hinet.com / jetcham.coil@msa.hinet.net