

Ignition Transformer

TYPE:TR05-S003

Applications:

- GAS IGNITER.
- AIR CLEANER.

※Remark:Below here which specific could depend on customized specifications are acceptable.

MECHANICAL DIMENSION:

UNIT mm

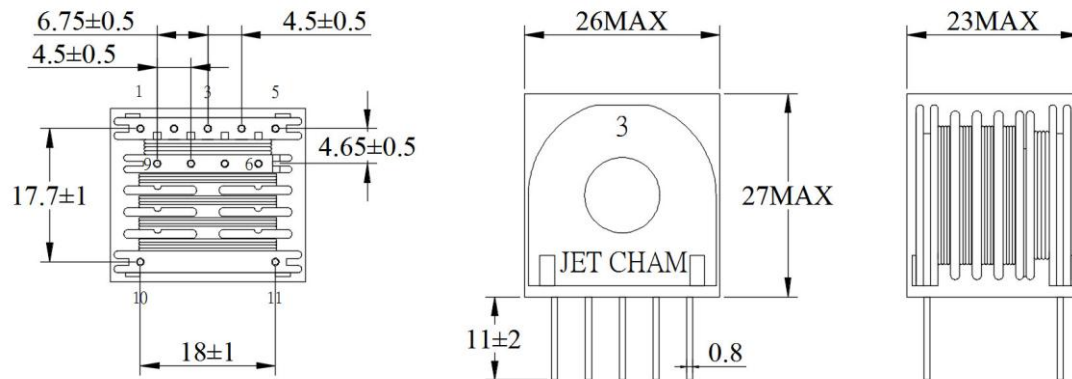

P/N	L _{pri.} (PIN1→PIN10)	L _{sec.} (PIN5→PIN11)	L _{pri.} (PIN1→PIN2)	L _{sec.} (PIN11→PIN5)	L _{pri.} (PIN4→PIN5)	L _{sec.} (PIN9→PIN11)	TURNS RATIO	WEIGHT
JC-105002	16μH±20%	27mH±15%					1:148	28 g
JC-105003	32μH±20%	27mH±15%					1:100	27 g
JC-105004			17μH±20%	528mH±15%			1:195	28 g
JC-105005					26μH±20%	150mH±15%	1:80	28 g

JET CHAM ENTERPRISE CO.,LTD

ADDRESS: 3F. NO.41 CHIAU AN ST. CHUNG HO DIST .NEW TAIPEI CITY, TAIWAN R.O.C.

OFFICE TEL:886-2-29253396 ~ 7 FAX.:886-2-29288877

FACTORY TEL:886-2-22447326 ~ 7 FAX.:886-2-22447328

E-mail: jetcham@ms35.hinet.com / jetcham.coil@msa.hinet.net