

High Voltage Transformer

TYPE:TR05-S001 UR-28

Applications:

- AIR CLEANER.
- ELECTRONIC OZONIZER.
- ELECTROSTATIC PRODUCTS.

MECHANICAL DIMENSION:

UNIT mm

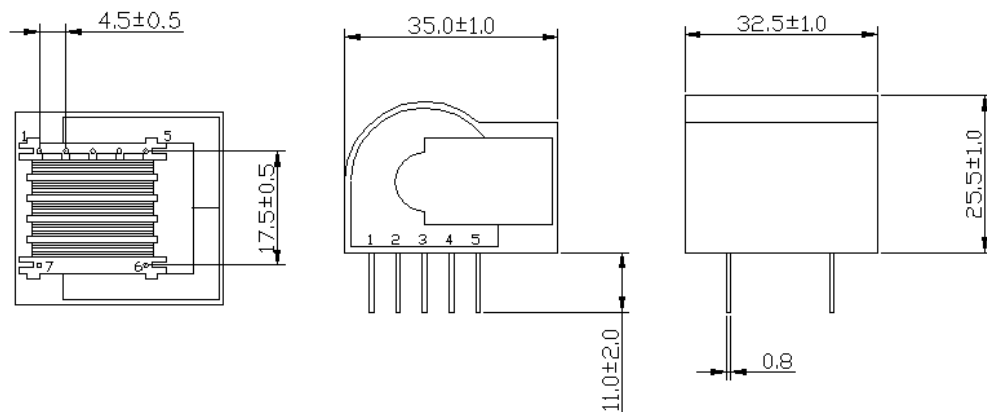

P/N	L (PIN1→PIN4)	L (PIN7→PIN6)	DCR (PIN1→PIN4)	DCR (PIN7→PIN6)			TURNS RATIO	WEIGHT
JC-89131-1	1.5mH±15%	1.75H±15%	600mΩ MAX	395Ω MAX			1:35	60 g
P/N	L (PIN2→PIN3) L (PIN3→PIN4)	L (PIN5→PIN1)	L (PIN7→PIN6)	DCR (PIN2→PIN3) DCR (PIN3→PIN4)	DCR (PIN5→PIN1)	DCR (PIN7→PIN6)	TURNS RATIO	WEIGHT
JC-99025	95μH±15%	6μH±15%	2.8H±15%	100mΩ MAX	36mΩ MAX	380Ω MAX	1:1:175	60 g

JET CHAM ENTERPRISE CO.,LTD

ADDRESS: 3F. NO.41 CHIAU AN ST. CHUNG HO DIST .NEW TAIPEI CITY, TAIWAN R.O.C.

OFFICE TEL:886-2-29253396 ~ 7 FAX.:886-2-29288877

FACTORY TEL:886-2-22447326 ~ 7 FAX.:886-2-22447328

E-mail:jetcham.coil@msa.hinet.net