

# Ignition Coil

TYPE:TR05-S001

## Applications:

- GAS IGNITER.
- AIR CLEANER.
- H.I.D STARTER 42 WATT LAMP MAX.

※Remark:Below here which specific could depend on customized specifications are acceptable.

MECHANICAL DIMENSION:

UNIT mm

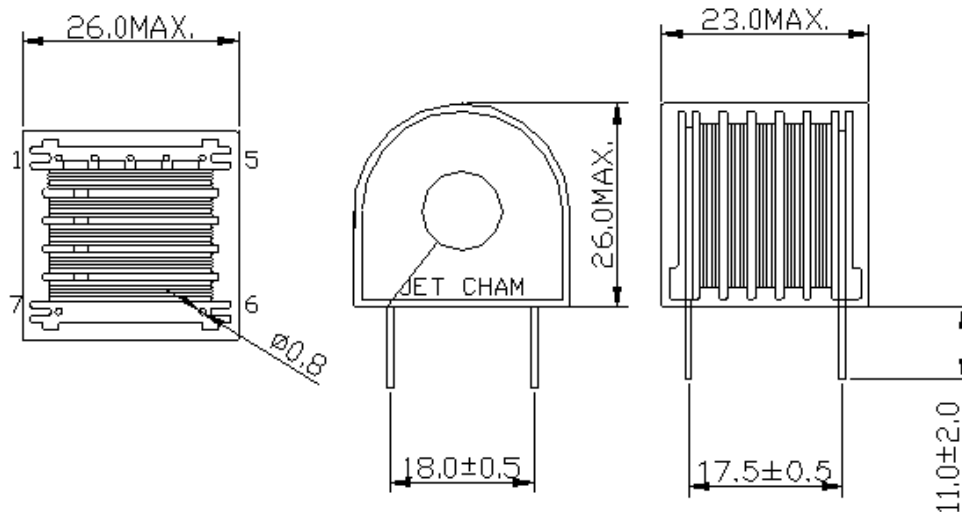

P/N	$L_{pri.}$	$L_{sec.}$	$DCR_{pri.}$	$DCR_{sec.}$	TURNS RATIO	WEIGHT
JC-88079	$16 \mu H \pm 20\%$	$400mH \pm 20\%$	100mΩ MAX.	1300Ω MAX.	1:195	31 g
JC-101012	$0.8\mu H \pm 15\%$	$2.6mH \pm 15\%$	10mΩ MAX.	4.0Ω MAX.	1:80	32 g
JC-10205A	$1.5\mu H \pm 15\%$	$2.25mH \pm 15\%$	10mΩ MAX.	3.5Ω MAX.	1:50	32 g

## JET CHAM ENTERPRISE CO.,LTD

ADDRESS: 3F. NO.41 CHIAU AN ST. CHUNG HO DIST .NEW TAIPEI CITY, TAIWAN R.O.C.

OFFICE TEL:886-2-29253396 ~ 7 FAX.:886-2-29288877

FACTORY TEL:886-2-22447326 ~ 7 FAX.:886-2-22447328

E-mail: [jetcham@ms35.hinet.com](mailto:jetcham@ms35.hinet.com) / [jetcham.coil@msa.hinet.net](mailto:jetcham.coil@msa.hinet.net)