

Ignition Coil

TYPE:TR04-S010

Applications:

- GAS IGNITER.
- AIR CLEANER.
- ELECTRONIC OZONIZER.

※Remark:Below here which specific could depend on customized specifications are acceptable.

MECHANICAL DIMENSION:

UNIT mm

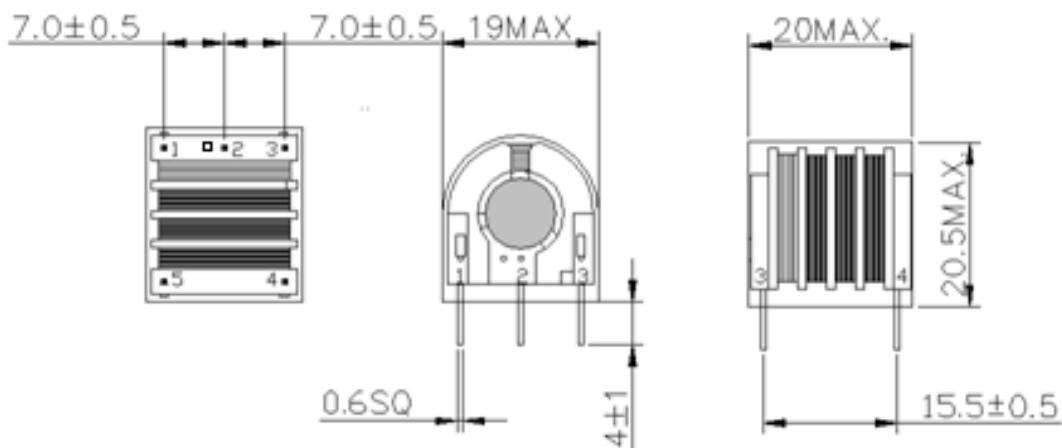

P/N	L _{pri.} (PIN2→PIN1)	L _{pri.} (PIN1→PIN2)	L _{sec.} (PN5→PIN1)	L _{sec.} (PN4→PIN3)	TURNS RATIO	WEIGHT
JC-98041	15μH±20%			172mH±20%	1:120	13.5 g
JC-10005		5.3μH±20%		230mH±20%	1:225	13.5 g
JC-101020			19μH±20%	330mH±20%	1:152	13.5 g

JET CHAM ENTERPRISE CO.,LTD

ADDRESS: 3F. NO.41 CHIAU AN ST. CHUNG HO DIST .NEW TAIPEI CITY, TAIWAN R.O.C.

OFFICE TEL:886-2-29253396 ~ 7 FAX.:886-2-29288877

FACTORY TEL:886-2-22447326 ~ 7 FAX.:886-2-22447328

E-mail: jetcham@ms35.hinet.com / jetcham.coil@msa.hinet.net